



All tests in this report are executed according to the ISO 9001 certified Quality management system of **BUILDWISE**

Buildwise Limelette
Buildwise Zaventem
Buildwise Brussels

B-1342 Limelette, Avenue P. Holoffe 21
B-1932 Zaventem; Kleine Kloosterstraat 23
B-1020 Brussel, Dieudonné Lefèvrestraat 17

Tel.: +32 (0)2 655 77 11
Tel.: +32 (0)2 716 42 11
Tel.: +32 (0)2 502 66 90

TEST REPORT

Unit	BUILDING PERFORMANCE AND RENOVATION	O/References	DE-BPR-0025/EXT BPR-24-077-03
-------------	-------------------------------------	---------------------	----------------------------------

Requested by	NOVATECH INTERNATIONAL NV MR. SJOBBE LUYTEN INDUSTRIELAAN 5B B-2250 OLEN		
Date of the order	5/6/2024	Samples registration	S2015-36-9
		Date of reception of samples	27/7/2015
Date of issue of the report	11/7/2024		
Test carried out	Injection product for the treatment of rising damp in masonry: Efficiency and migration of the product "WP7-402"		
Location of tests	Buildwise Limelette		
References	NBN EN 1925 (1999) "Natural stone test methods - Determination of water absorption coefficient by capillarity" TIN 252: Humidity in buildings. Treatment of rising damp, Buildwise, 2014		

Disclaimer

Buildwise is not responsible for the accuracy and completeness of the information provided by the customer and taken over in this report. The sampling was not carried out by Buildwise and thus the results of this report apply only to the sample as received. The equivalence between the tested product covered by this report and the commercialised product lies entirely under the responsibility of the requestor.

This test report contains 5 pages. This test report may only be reproduced in its entirety.

- No sample
- Sample(s) subjected to destructive test
- Sample(s) to be removed 30 calendar days after sending of the report, save in the case of a further written request.

AUTHORISED BY :
R&D Expert
Yves Vanhellemont

1. Description of the test procedure

The test procedure was developed by Buildwise at the request of the Belgian Association for Technical Approval (UBAAtc). It is based on the results of the SSTC pre-normative research (Effectiveness of injection products against rising damp – NM /G2 /04) and of the collective research “*HUMIBATI - Traitement de l'humidité ascensionnelle - Innovation, Performances et Environnement*”, 2010-2012 and is briefly described below.

1.1 Salt solution

The salt solution mentioned below is a solution of the following salts in water:

- 0.5 mass % NaCl
- 0.5 mass % KNO₃
- 2 mass % Na₂SO₄

1.2. Test specimens

The test specimens are manufactured calcium silicate blocks (Silka-kalkzandsteen from Xella) with the following characteristics:

- total porosity: 28.0 %
- mass density: 1.85 g/cm³

Prior to the tests, the blocks undergo total carbonation in a container with a high CO₂ content. A phenolphthalein test on a freshly split block, confirms this complete carbonation before the tests (pH lower than 10).

After carbonation, the test procedure is carried out on test specimens (half blocks) with dimensions ≈ 54 x 100 x 100 mm³. A cavity (diameter 20 mm, depth 70 mm) is first drilled into the centre of the specimens and thoroughly (by brushing and compressed air) prior to the application of the products.

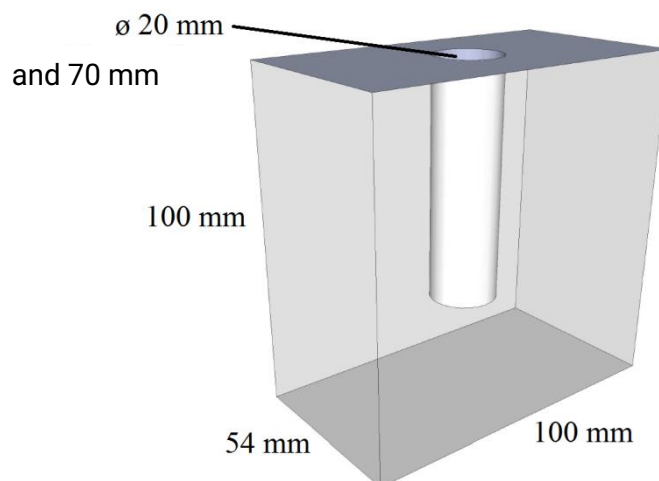

1.3. Characterisation of the specimens

After drying at $45 \pm 5^\circ\text{C}$ and determination of the dry mass of each specimen (m_{nd}), the degree of saturation of the samples is determined by capillary absorption. This absorption is limited to 24 hours and is carried out using a salt solution according to NBN EN 1925 (1999), through the non-moulded face measuring $\approx 100 \times 100 \text{ mm}^2$ ($10 \pm 2 \text{ mm}$ water height). The test is conducted under laboratory conditions at $23 \pm 3^\circ\text{C}$ and $50 \pm 5\% \text{ RH}$. The capillary saturation value after 24 hours in the untreated test specimens results from the difference between the measured wet mass after 24 hours and the initial dry mass ($m_{n24} - m_{nd}$).

1.4. Specimen preparation and product application

The specimens are preconditioned in order to obtain saturation values which are a fraction of the capillary saturation value ($m_{n24} - m_{nd}$). Three specimens with a saturation degree of $40 \pm 5\%$, three samples with a saturation degree of $60 \pm 5\%$ and three samples with a saturation degree of $80 \pm 5\%$ of the capillary saturation value are prepared. On average, these values correspond to a moisture content of respectively 5.2 %, 7.8 % and 10.4 % of the mass of the calcium silicate samples. In order to obtain these saturation values, the specimens are left to dry after the capillary absorption test (see 1.1.3.), until the required saturation value is reached.

In order to obtain a uniform moisture distribution, the specimens are then individually stored in water- and airtight containers for 7 days, at a temperature of $23 \pm 3^\circ\text{C}$. This individual storage avoids unwanted product transfers in a gaseous form.

After this conditioning, the specimens are weighed once more to determine their real saturation value, given as a percentage of the capillary saturation value.

Each conditioned specimen is then treated with the injection product, by applying it into the cavity.

The amount of product to be applied is the following:

- If the manufacturer indicates that the quantity of product to be applied equals 10 liters of injection product per square meter of horizontal wall section, then 16 ml of product will be applied into the cavity of each specimen.
- If the manufacturer recommends other product quantities, the amount of product to be applied in each cavity is calculated proportionally to the above mentioned product quantities.
- If the manufacturer does not provide guidelines for a liquid injection product, 16 ml of product are applied in each cavity.

Considering the volume to be treated, the product quantity applied in each cavity roughly corresponds to one quarter of the product quantity prescribed by the manufacturer. This proportion is kept constant for all products in this procedure, and allows a better comparison between them.

When products in the form of a crème or gel are being tested, a very small amount of product will be applied. From this small dot of product, the product has to migrate into the substrate, through a 'spherical' migration. In reality, the situation is less severe: such a product will fill the entire borehole, from which a 'cylindrical' migration is expected, in which the product has to migrate less far to treat the substrate. Therefore, since 2015, an alternative filling system has been employed. After the application of the product, a cylinder with a slightly smaller diameter is inserted into the borehole. Using a screwing system, the cylinder is inserted until a depth where the product is about to be pushed out of the borehole. As such, the walls of the borehole will be 'humidified' with the product, enabling the product to migrate cylindrically, as happens in real cases.

After application of the product, the specimens are individually stored in water- and airtight containers during 28 days, at a temperature of $23 \pm 3^\circ\text{C}$. This individual storage avoids unwanted product transfers in a gaseous form.

1.5. Measurement of the product performance

After 28 days of conditioning, the specimens are removed from their sealed container and stored for 7 days under laboratory conditions at $23 \pm 3^\circ\text{C}$ and $50 \pm 5\%$ RH.

They are subsequently submitted to a capillary water absorption test in demineralised water according to NBN EN 1925 (1999), through the unmoulded surface $\approx 100 \text{ mm} \times 100 \text{ mm}$ ($10 \pm 2 \text{ mm}$ water height). The test is conducted under laboratory conditions at $23 \pm 3^\circ\text{C}$ and $50 \pm 5\%$ RH. The total test duration is limited to 24 hours (and equals the duration applied in the initial absorption test).

This first absorption test on the treated specimens is followed by oven drying at $45 \pm 5^\circ\text{C}$ and weighing of the specimens, in order to obtain the dry mass after treatment (m_{td}). Drying is followed by a second capillary test under the conditions described above and again, weighing of the specimens after 24 hours (m_{t24}). These two final results provide us with the capillary absorption of the treated specimen ($m_{ta} = m_{t24} - m_{td}$).

$$\text{Absorption factor (\%)} = 100\% \times (1 - (m_{t24} - m_{td}) / (m_{n24} - m_{nd}))$$

Note: The efficiency is measured after two wetting/drying cycles as described above, to eliminate the parasitic moistening effects caused by emulsifying agents added to aqueous formulations to stabilise emulsions.

1.6. Potential product migration

The aim of this test is to assess the migration potential of the test product in the calcium silicate specimens at different saturation degrees (40, 60 and 80% of the capillary saturation value after 24 hours).

The test is carried out on the specimens that were used to evaluate the efficiency by absorption and includes:

- Diamond cutting of the specimens in a plane parallel to the $100 \times 100 \text{ mm}^2$ surface and passing through the axis of the cavity;
- Cleaning of the cutting planes and drying of the specimens at $45 \pm 5^\circ\text{C}$;
- Capillary absorption in 5 mm of demineralised water through the outer surface ($\approx 100 \times 100 \text{ mm}^2$), with the cutting plane upwards;
- After 3 hours, indication of the treated surface in the cutting plane (surface that remains visually dry), photography of the specimens and evaluation of the concerned surfaces with the help of visual analysis software.

The migration potential is calculated according to the formula given below and given individually for the three tested saturation degrees, based on the average of the two corresponding half specimens.

$$\text{Migration factor (\%)} = 100 \times (\text{treated area} / \text{total area})$$

2. Efficiency results for the product « WP7-402 »

Product quantity applied in the specimens

Based on the procedure described in paragraph 1.1.4 and the technical data sheet for the product "WP7-402", which prescribes 1.25 l per square meter of horizontal section of masonry, the specimens were treated with 2 ml of ready-mixed product.

Initial product efficiency for the product "WP7-402 "

Potential initial efficiency ^(*) of the product " WP7-402 "	Moisture content of the specimen at the time of product application (percentage of the capillary saturation value after 24 h)		
	40%	60%	80%
Reduction of capillary absorption	76%	65%	60%
Migration in the specimen	69%	63%	67%
New class (new classification, since 2013)	Class A+	Class A+	Class A+

(*) average values. The classes are given according to the tables below.

Since 2013, a new and simplified classification is being used. This classification is based mainly on the efficiency factor, since it has been observed that migration and efficiency are highly correlated. The migration criterium has therefore been brought back to a single value. The interpretation of the new classification can be found in the following table:

New classification			
Class	Efficiency	Migration	Evaluation
A+	≥ 60%	≥ 25%	Highly efficient product
A	≥ 40% and < 60%		Very efficient product
B	≥ 20% and < 40%		Efficient product
C	< 20%	< 25%	Does not meet the requirements

Remark: because of the application of a significant smaller amount of product, compared to quantities applied in real cases, the measured efficiency will be also significantly lower as the expected efficiency in real cases. It is therefore of the utmost importance to perform the interpretation of the test results, using the lower table, particularly the right column: a product which is categorized as at least efficient, will offer a good protection when applied in real cases. We refer to NIT 252 for additional information.